

GLENFOREST

with eternal
Beauty and Beyond

PRADHAN GLENFOREST

OPP. UMA SOCIETY, BS. VRUND RESIDENCY,
NARAYAN GARDEN ROAD, NEW GOTRI, VADODARA.

CALL : 9712080801

E-MAIL : PRADHANDVELOPMENTS@GMAIL.COM

DEVELOPERS :

PCG INFRASPACE PRIVATE LIMITED

ARCHITECT :



STRUCTURE :



PLUMBING :

*Krupalu
Consultant*

ELECTRICAL



Above project is registered under Gujrera. for further details :
visit: www.gujrerar1.gujarat.gov.in under registered project.

RERA REGISTRATION NO.

PR/GJ/VADODARA/VADODARA/Others/RAA10696/270922

PRADHAN GLENFOREST

5BHK PREMIUM FLATS

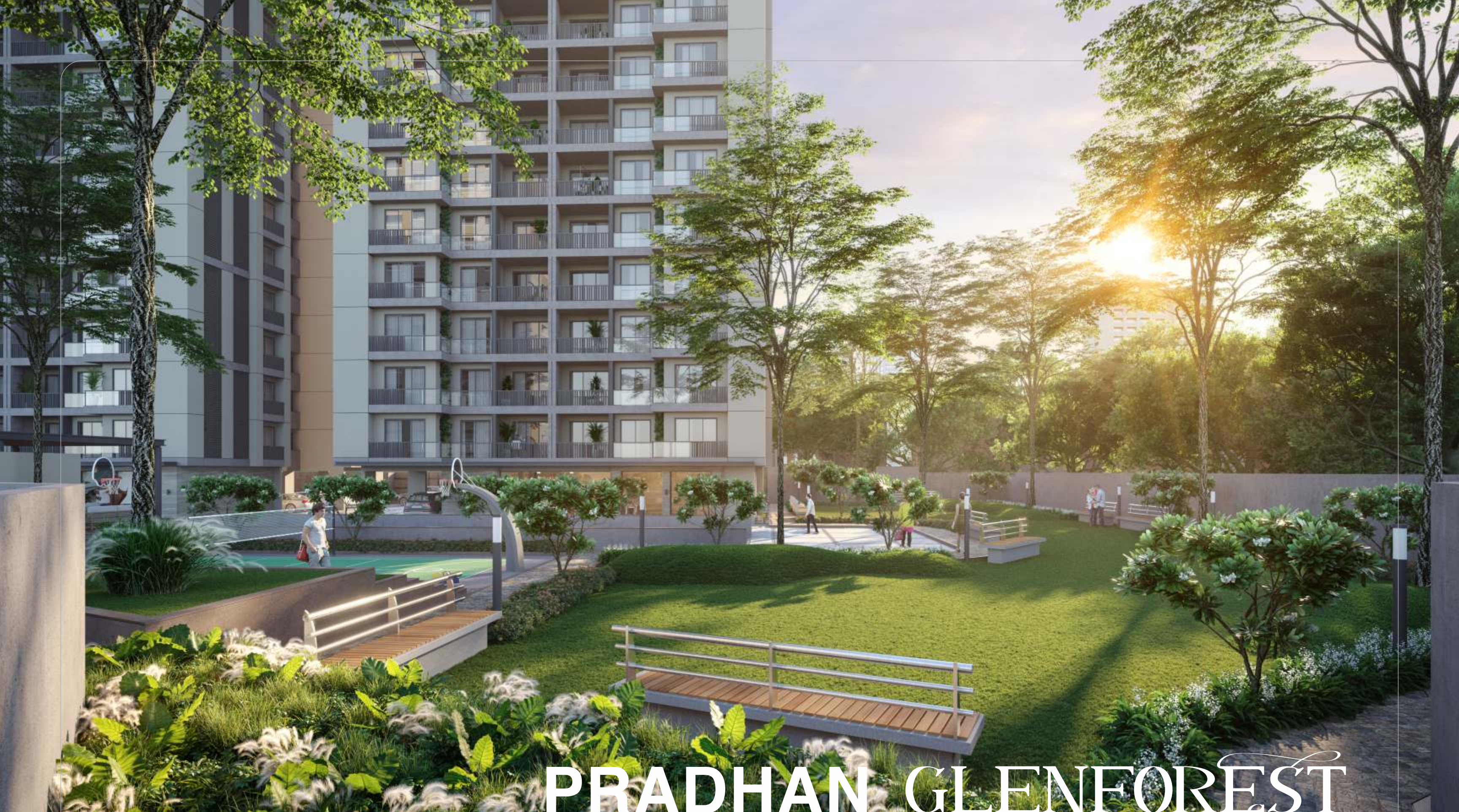

PRADHAN GLENFOREST



DESIGN STUDIO
architects & interiors
RUCHIR SHETH

At Pradhan Glenforest, living spaces go beyond just luxury to become personal statements that embody your inner style. Where even the minutest of details are crafted to place you in an elite league, a cut above the rest.

An innovative design offers the tower both a spectacular facade and functional excellence. The ultra-luxurious 5 BHK Apartments and Penthouses with expansive layouts and wide open balconies ensure unparalleled ambience and comfort. Premium leisure amenities are thoughtfully handpicked for a life less mundane. All these indulgences are nestled inside a gated community for enhanced safety and exclusivity.

A CULTURE OF



LIFESTYLE

- Multipurpose Hall
- Gymnasium
- Swimming Pool
- Library Room
- Indoor Game
- Amphi Theatre

Be, feel and live the privileged life >>

FREEDOM
TO CHERISH WHAT
YOU'VE DESIRED

G + 14 Storeyed residential tower with **108 units**
Thoughtfully planned **residences**
Located at **New Gotri.**



FREEDOM
TO EXPERIENCE
THE BEST THINGS IN LIFE

In modern times where space is the ultimate luxury, imagine living in a palatial home that fulfils all your wants and wishes. Feel the sense of openness, bliss and happiness like never before.



**Elegant
Apartments**



**Exclusive
Amenities**



**Premium
Lifestyle**

A

B

C

D





FREEDOM TO INDULGE IN MODERN AMENITIES



GARDEN



BANQUET
HALL



GAMES
ROOM



LIBRARY



LOUNGE
ROOM



TODDLERS
ROOM



GYM
ROOM



DISCO
THEQUE



MINI
THEATRE



KIDS
PLAY AREA



AMPHI
THEATRE



GAZEBO



SWIMMING
POOL



PLAY
COURT



INFINITY
POOL



WAITING
AREA

WHERE HAVING ONE BALCONY
IS A DREAM FOR MANY,
PRADHAN GLENFOREST OFFERS YOU FOUR





BASEMENT FLOOR LAYOUT PLAN

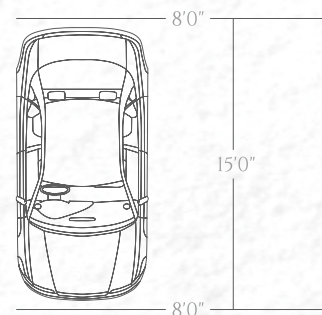

- 01 | LIFT
- 02 | PUMP ROOM
- 03 | U.G.W.T. (DOMESTIC)
- 04 | U.G.W.T. (FIRE)





GROUND FLOOR LAYOUT PLAN

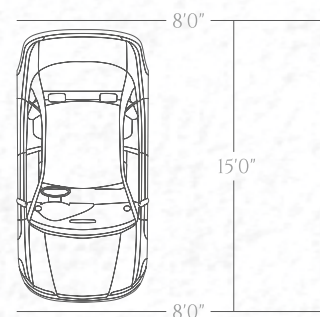

- | | | | | | |
|----|----------------|----|-------------------|----|---------------------|
| 01 | GARDEN | 12 | AMPHI THEATRE | 23 | INFINITY POOL |
| 02 | BANQUET HALL | 13 | GAZEBO SITTING | 24 | DECK AREA |
| 03 | PANTRY | 14 | SWIMMING POOL | 25 | SPECTATOR SEATING |
| 04 | GAMES ROOM | 15 | PLAY COURT | 26 | JOGGING TRACK |
| 05 | LIBRARY | 16 | CHANGING ROOM | 27 | METER ROOM |
| 06 | LOUNGE ROOM | 17 | WAITING ROOM | 28 | VISITOR PARKING |
| 07 | TODDLER'S ROOM | 18 | ENTRANCE GATE | 29 | TWO WHEELER PARKING |
| 08 | GYM ROOM | 19 | ENTRANCE PLAZA | 30 | ALLOTTED PARKING |
| 09 | DISCO THEQUE | 20 | BUS PICK-UP POINT | 31 | FLOWER BED |
| 10 | MINI THEATRE | 21 | SECURITY CABIN | 32 | THICK PLANTATION |
| 11 | KIDS PLAY AREA | 22 | ADMIN OFFICE | | |





TYPICAL FLOOR
LAYOUT PLAN





5 BHK UNIT FLOOR PLAN

Built Up Area :- 2352.0 sq.ft.
 Super Built Up Area :- 3762.0 sq.ft.



4B2HK UNIT FLOOR PLAN

Built Up Area :- **2352.0** sq.ft.
Super Built Up Area :- **3762.0** sq.ft.



3B2HK UNIT FLOOR PLAN

Built Up Area :- 2352.0 sq.ft.
 Super Built Up Area :- 3762.0 sq.ft.





ADDITIONAL SPECIFICATIONS



ALLOTTED PARKING



PICK UP AREA



ENTRANCE PLAZA



SECURITY CABIN



24X7 CCTV SURVEILLANCE



VIDEO DOOR SYSTEM



POWER BACK UP



PANTRY



WATER PROOF



ANTI-TERMITE TREATMENT



TWO ELEVATORS PER TOWER



FIRE SAFETY SYSTEMS





SPECIFICATION



Structure

- Earthquake resistant RCC frame structure designed by approved Structural Consultant.



Wall finish

- Interior : Smooth / Mala finish plaster with two coat putty and primer
- Exterior : Double coat plaster with weather resistant texture paint.



Flooring

- Premium quality glazed vitrified tiles in All Rooms
- Anti-Skid tiles flooring in all Bathrooms.



Doors

- Main Door : High quality decorative door on both sides veneer finish and wooden frame.
- Internal Doors : Laminated flush door with Premium quality lock fittings.



Kitchen

- Premium quality granite / full body tile platform with S.S. sink & Dedo tiles.



Bathroom

- Designer Bathrooms with premium quality bath fittings and sanitary wares.
- Premium quality ceramic tiles dedo



Electrification

- Concealed copper wiring as per ISI standard.
- Adequate electric points in each room as per Architect's plan
- Geyser points in each bathroom.
- TV point in Living Room and All Bedrooms.
- AC point in Living Room and All Bedrooms.
- Separate MCB for each room.



Windows

- Aluminium powder coated with mosquito net.



Terrace

- Elegant tiles finish with water proofing treatment.



Lift

- 2 Passenger Lift in each tower



LOADED WITH
REPUTED BRANDS
(& EQUIVALENT)

Jaquar
experience bathing

KOHLER.

CERA

asianpaints

JK LAKSHMI
CEMENT

UltraTech
CEMENT
The Engineer's Choice

RR KÄBEL

NEOCAB
Wires & Cables

ANCHOR
by Panasonic

Schneider
Electric

EUROPA
THE REAL SECURITY

Godrej

ASTRAL
PIPES

Finolex



IN THE VICINITY OF 10 MINS.

- GMERS Gotri
- Inorbit Mall
- Doggers Park
- Grocery Stores
- Hyatt Hotel
- Bhailal Amin Gen. Hospital
- Educational Institute
- ATM
- ISKON Temple
- Brand Factory
- Petrol pump



PAYMENT TERMS:

10% at the time of Booking | 10% at the time of Banakhat | 15% Plinth Level | GF slab to 14th floor slab (15) 50%
5% Masonry & Plaster work | 5% flooring & fitting | 5% Completion \ Before saledeed

CANCELLATION POLICY :

Cancellation charges Rs. 1,00,000/-, if agreement for sale is executed then cancellation charges will be Rs. 2,20,000/-, refund of any sort will be given after new booking of same premise.

TERMS AND CONDITION / DISCLAIMER :

- (01) The Booking of the unit is confirmed only after receiving 30% of total cost, till then it will be treated as advance for allotted unit.
- (02) Possession will be given after one month of settlement of all account. Also vastupuja, furniture work will be permitted only after possession.
- (03) Development charges, Stamp duty, GST Common maintenance charges, Legal charges, MGVCL, VMSS/VUDA charges will be paid by the purchaser.
- (04) Any new central or State Gov. Taxes, is applicable shall have to borne by purchaser.
- (05) Payment dues are to be paid within 7 days from the date of completion of each stage of work or as per commitment.
- (06) For delay in payment as per the above schedule, Interest as per RERA will be charges extra. If the due/committed payment is delayed continuously for more than 90 days, the developer reserves all rights to cancel that booking by giving simple notice.
- (07) Developers shall have the right to change the plan, elevation, specification or extend the scheme or any details herein will be binding to all.
- (08) In case in the procedure or any activity of corporation/VUDA, MGVCL or any authority shall be faced united.
- (09) Extra work shall be executed only after receiving full payment in advance-subject to approval.
- (10) Any kind of alteration or change is strictly not allowed inside or outside of unit which affect the elevation or outer look or strength on the unit or project.
- (11) Any plans, specifications or information in this brochure cannot form legal part of an offer, contract or agreement. It is only depiction of the project.
- (12) All images shown are for Illustration purpose only.
- (13) All disputes are subject to Vadodara Jurisdiction.